



SOSEN LED Driver, Your Smart Choice

Specifications

SS-200NL-E Series LED Driver

Model: SS-200NL-E260*

Description: 200W LED Driver

Rev.: V02

Release Date: 2023-02-01

SS-200NL-E Series LED Driver

SOSEN
LED DRIVER



LED DRIVER

NL-E Series



Features:

- Efficiency up to 95%
- Dimming: 0-10V,PWM,Resistor
- Protections: SCP/OTP/OVP
- Surge protection: CM: 6kV, DM: 6kV
- Warranty: 5 years



Class P

Description :

SS-200NL-E series are 200W non-isolated constant current LED Driver with 90-305VAC. It has high efficiency, compact housing ,fullypotted , high reliability, high cost performance and other advantages.

Applications:

Wall washers, Linear high bay light, Flood lighting, Wall lamp

Model List:

Model	AC Input Range	Max. Pout	Vout Range	Full Power Vo Range	Iout	THD(Typ.)	PF(Typ.)	Eff.(Typ.)	Max.Tc
SS-200NL-E260*	90-305Vac	200W	180-260V	200V-260V	0.77-1A	8%	0.97	95%	90°C

Note:

1.Default Tested: at 220Vac, full load, Ta 25°C.

2.The performance of the LED Driver can be guaranteed within the full power Vo range.The voltage lower than full power Vo range, it is need to test the performance with the LED module;

SS-200NL-E Series LED Driver

“*” Means Additional Function

“*”	DALI (suffix:D)	AUX 12V (suffix:H)	Timing (suffix:T)	0-10V/PWM /Resistor (suffix:B)	Remark
No Suffix					
B				✓	

Input Characteristics:

Parameter	Min.	Typ.	Max.	Remark
Rated AC Input Range	100Vac		277Vac	Ref. derating curve
AC Input Range	90Vac		305Vac	Ref. derating curve
Input Frequency Range	47Hz	50/60Hz	63Hz	
Max Input Current			2.3A	100Vac, Full load
Max Input Power			230W	100Vac, Full load
Max Inrush Current(120Vac)			60A	Cold start
Max Inrush Current(220Vac)			100A	Cold start
Max Inrush Current(277Vac)			130A	Cold start
No Load Power			5W	220Vac/50Hz, No Load
Power Factor	0.95	0.97		220Vac/50Hz, Full load
	0.90			100-277Vac/50Hz, 70%-100% load
THD		8%	10%	220Vac/50Hz, Full load
			20%	100-277Vac/50Hz,70%-100% load

SS-200NL-E Series LED Driver

Output Characteristics:

Parameter	Min.	Typ.	Max.	Remark
O/P Voltage Range	180V		260V	Power derated @180-200V
Rated O/P Voltage	200V		260V	$P_o = V_o \cdot I_o = 200W$, Full load
Rated O/P Current	0.77A		1A	1A for 200V, 0.77A for 260V
Adj. O/P Current (AOC) Range	0.7A		1A	
No Load Voltage			310V	
Efficiency @120Vac	90.0%	92.0%		Output 260V/0.77A
Efficiency @220Vac	93.0%	95.0%		Output 260V/0.77A
Efficiency @277Vac	93.0%	95.0%		Output 260V/0.77A
O/P Current Tolerance	-5%		+5%	
O/P Current Ripple(PK-AV)		5%	10%	Full load
Start-up Current Overshoot			10%	Full load
Start-up Time			1.5S	120Vac, Full load
			1.0S	220Vac, Full load
Line Regulation	-2%		+2%	Full load
Load Regulation	-6%		+6%	
Temperature Coefficient	-0.05%/°C		+0.05%/°C	Tc: 0°C~90°C
OTP	90°C	100°C	110°C	> Tc Typ., Current derating < Tc Min., Current recovery
Short Circuit Protection				Driver will not be damaged

SS-200NL-E Series LED Driver

Other Characteristics:

Parameter		Min.	Typ.	Max.	Remark
0-10V Dimming	Dim Vmax	0V		12V	DIM+ source current 100uA.
	Dim Range	10%Iomax		100%Ioset	Dimming prohibits reverse connection
	Rec.Dim Range	0V		10V	
PWM Dimming	PWM High	9.8V		10.2V	DIM+ source current 100uA.
	PWM Low	0V		0.3V	Dimming prohibits reverse connection
	Frequency	1KHz		2KHz	
	PWM Duty	0%		100%	
Resistor Dimming	Resistance	0Kohm		100Kohm	DIM+ source current 100uA.
	Dim Range	10%Iomax		100%Ioset	
Dim-to-Off	Dim off	0.6V	0.7V	0.8V	
	Dim on	0.8V	0.9V	1.0V	
Lifetime(Tc≤75°C)		≥50,000 hours			80% load,220Vac
MTBF		200,000 hours			220Vac,Full load, Ta=25°C (MIL-HDBK-217F)
Tc		90°C			
Warranty		5 years			Tc : 75°C
Net Weight		530g			
Dimension		197mm*45mm*34mm			L x Wx H

NOTE: All the parameters above are tested Ta 25°C and LED load, unless specified.

SS-200NL-E Series LED Driver

Environmental Requirements

Parameter	Min.	Typ.	Max.	Remark
Operating Temperature(Tcase)	-40°C	25°C	+90°C	
Storage Temperature	-40°C	25°C	+90°C	
Operation Humidity	10%RH		90%RH	
Storage Humidity	5%RH		95%RH	
Altitude	-65m		4000m	

Safety and EMI/EMS Standards

Certification	Standard	Status	Remark
UL/cUL	UL8750	✓	
TUV	EN 61347-2-13:2014/A1:2017 EN61347-1:2015 EN62493:2015		
RCM	AS/NZS61347.2.13		
BIS	IS15885:2012 Part 2 Sec 13		
CCC	GB 19510.14-2009	✓	
CE	EN 61347-2-13:2014 EN61347-1:2008+A1:2011+A2:2013		

EMI/EMS	Criterion	Remark
Conduction Emission	EN IEC 55015:2019+A11:2020	
Radiation Emission	EN IEC 55015:2019+A11:2020	
Harmonic Current Emissions	IEC/EN 61000-3-2:2019+A1:2021	Class C
Surge	IEC/EN61000-4-5	DM: 6kV,CM: 6kV,Criterion B
Ring Wave	IEC/EN 61000-4-12	DM: 6kV,CM: 6kV,Criterion B

SS-200NL-E Series LED Driver

Safety Test Items:

Safety Test Items	Technical Indicators		Remark
Insulation Requirements	UL Insulation Requirements	TUV Insulation Requirements	
Input-Case	1600Vac	1500Vac	Basic insulation
Input-Dim	1600Vac	3000Vac	Reinforced insulation
Dim-Case	500Vac	250Vac	Basic insulation
Insulation Resistance	≥10MΩ		Input-Dim, Test voltage:500Vdc
Ground Resistance	≤0.1Ω		25A/1min
Leakage Current	≤0.75mA		277Vac

NOTE:

1. SOSEN warrants the LED Driver itself complies with EMC standard. However, LED Driver's EMC should be re-checked when integrated into lighting systems due to unexpected interference of components.
2. Please short (ACL and ACN), (V+ and V-), (Dim+ and Dim -) when Hi-pot test.
3. During the HI-POT, the built-in GDT and the ground connection terminal wire shall be disconnected.

Performance Curves:

Input Inrush Current

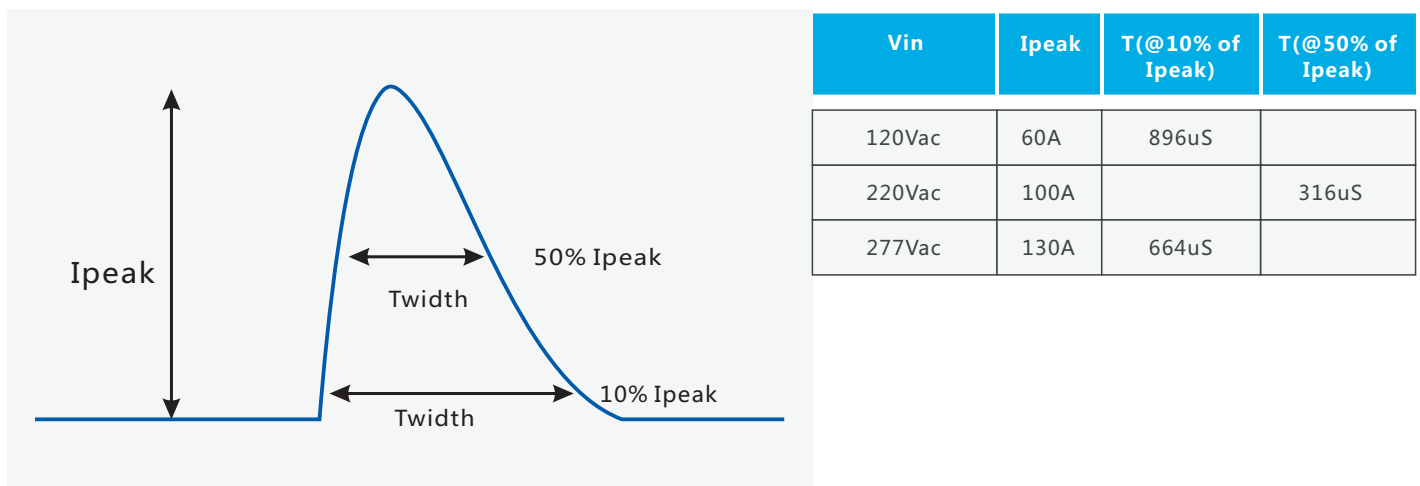

SS-200NL-E Series LED Driver

Performance Curves:

Output Voltage Vs. Output Current(Dim/AOC Window)

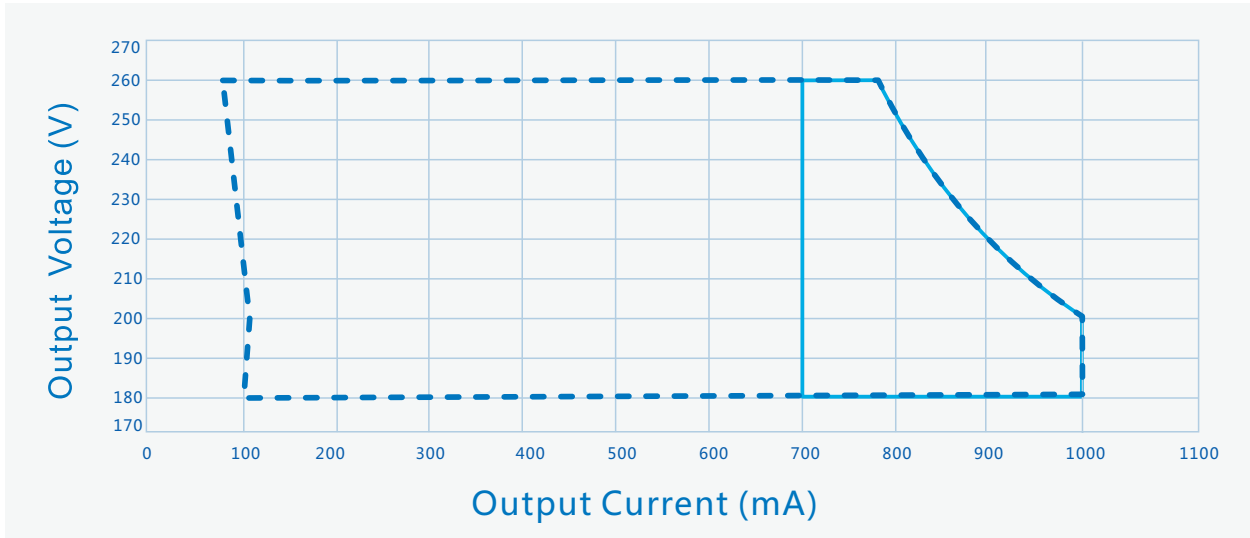

----- Dimming Window ————— AOC Window

Efficiency Vs. Output Voltage (Vin=120Vac)

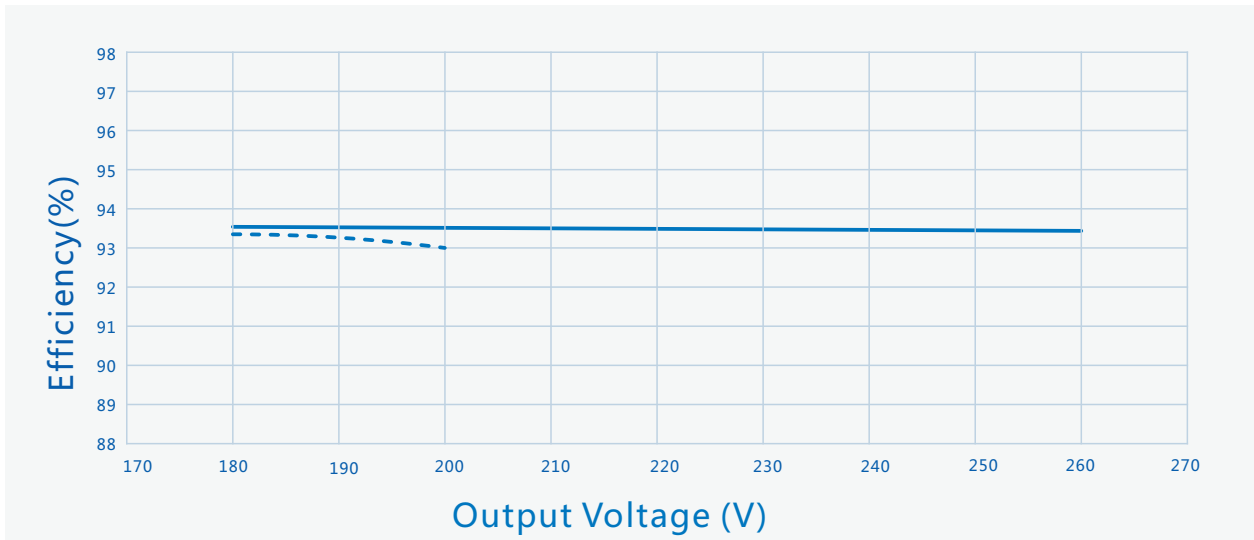

----- Io=1000mA ————— Io=770mA

SS-200NL-E Series LED Driver

Performance Curves:

Efficiency Vs. Output Voltage ($V_{in}=220V_{ac}$)

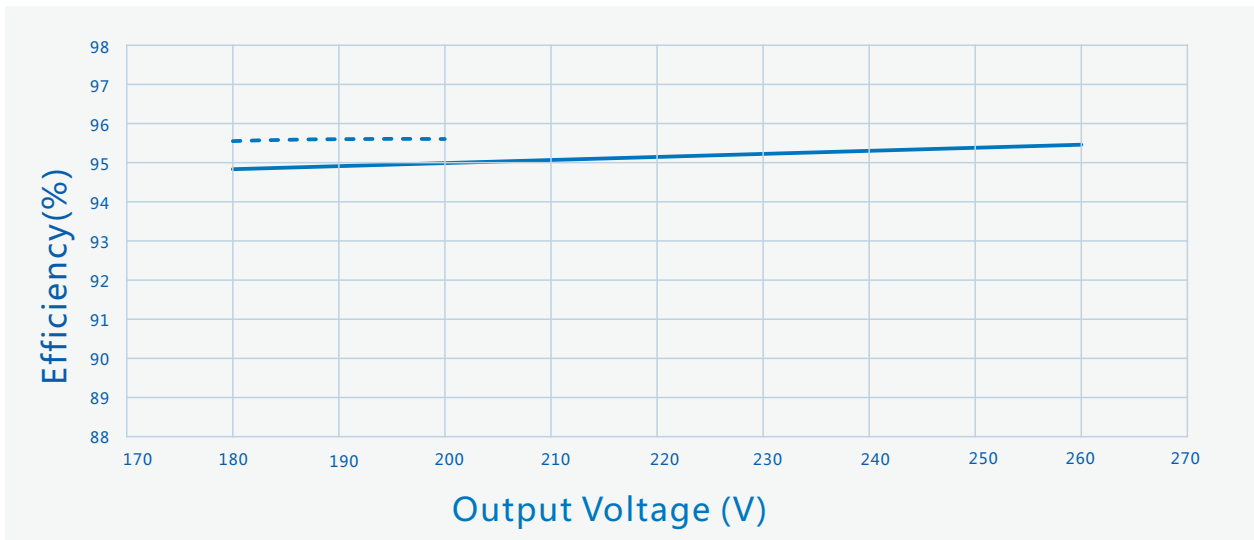

----- $I_o=1000mA$

————— $I_o=770mA$

Efficiency Vs. Output Voltage ($V_{in}=277V_{ac}$)

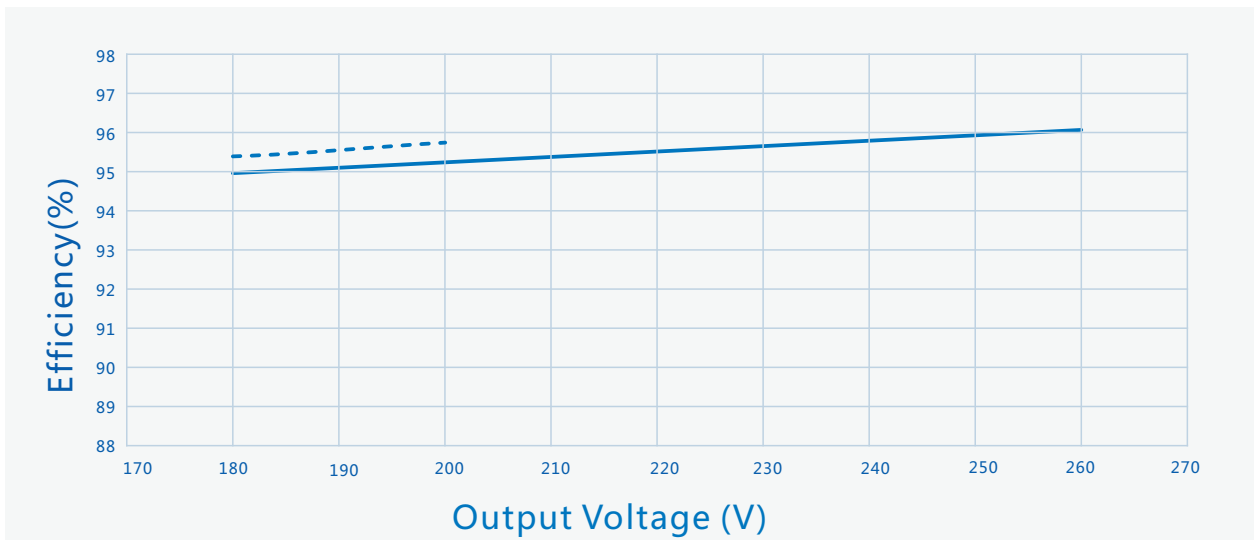

----- $I_o=1000mA$

————— $I_o=770mA$

SS-200NL-E Series LED Driver

Performance Curves:

Power Factor Vs. Output Power

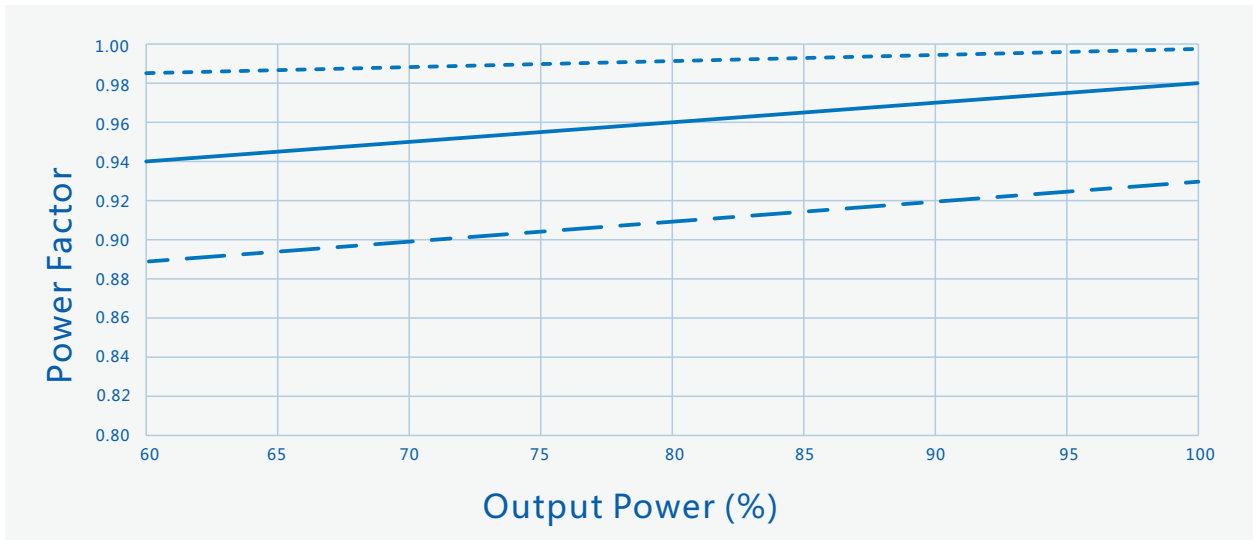

----- Vin=120Vac ————— Vin=220Vac - · - · Vin=277Vac

THD Vs. Output Power

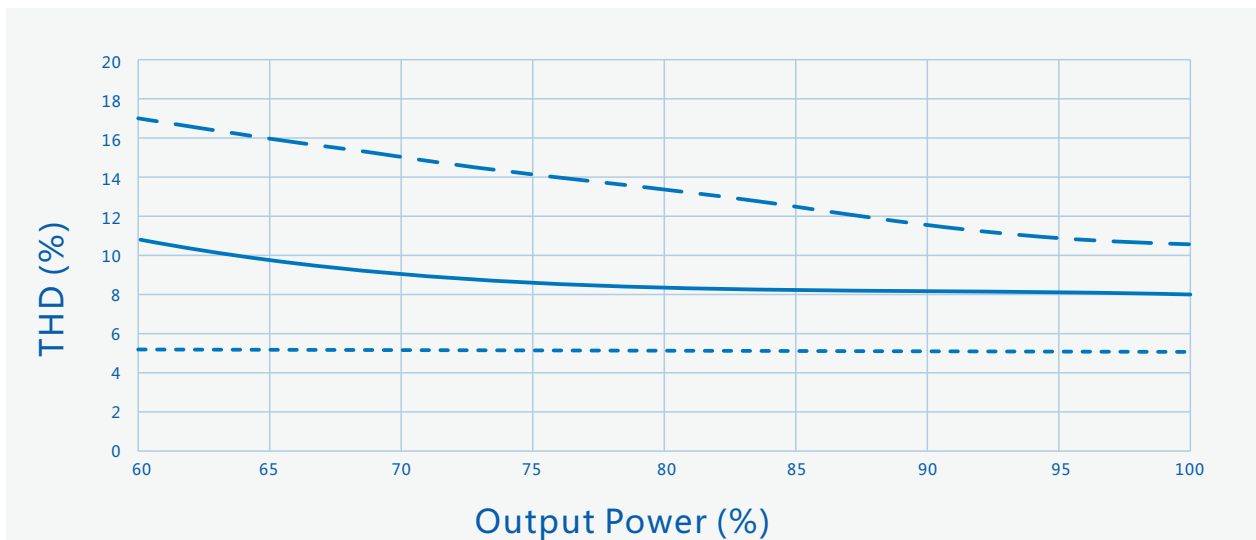

----- Vin=120Vac ————— Vin=220Vac - · - · Vin=277Vac

SS-200NL-E Series LED Driver

Performance Curves:

Output Power Vs. Input Voltage

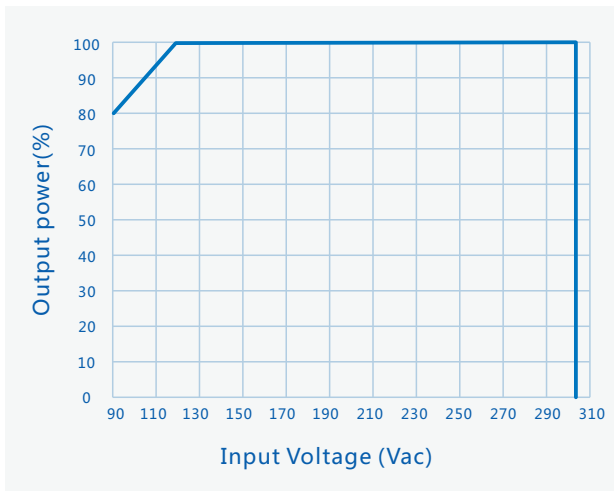

Output Power Vs. Case Temperature

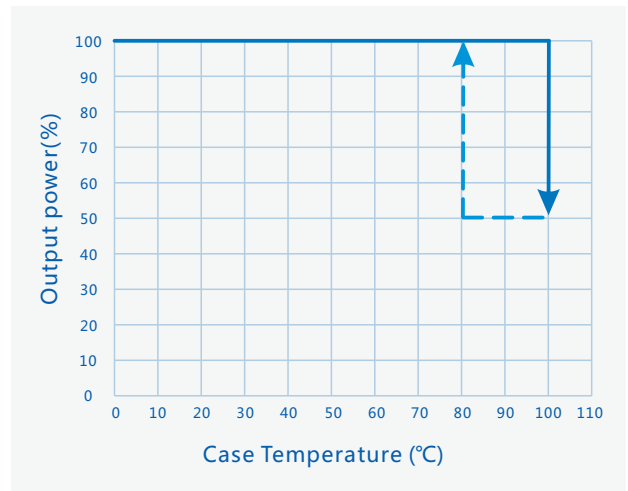

Output Power Vs. Dimming

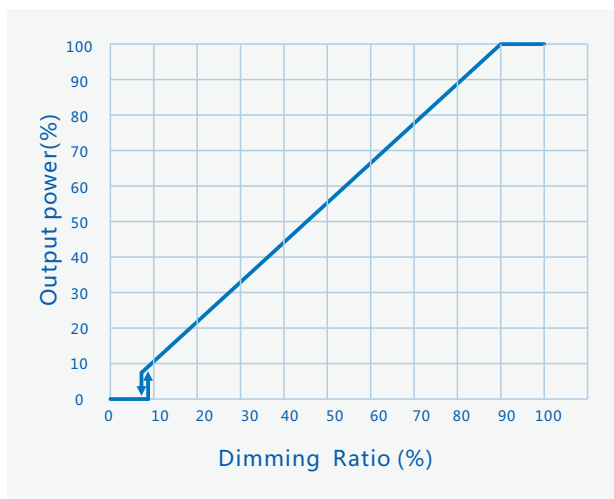

Lifetime Vs. Case Temperature

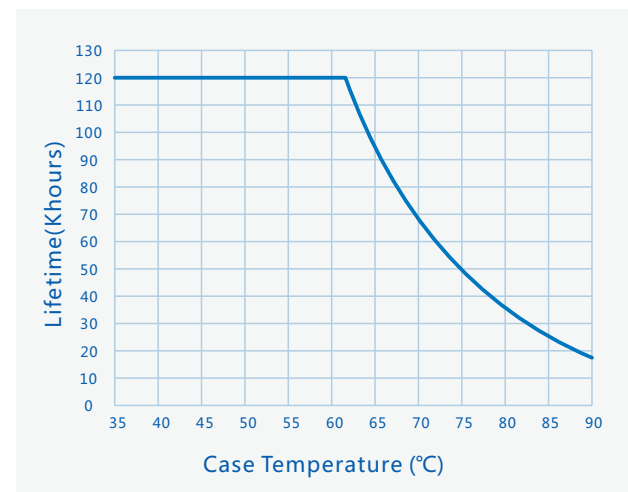

SS-200NL-E Series LED Driver

Mechanical Characteristics

INPUT

ACL

ACN

SPD

AOC



V+

V-

DIM+

DIM-

OUTPUT

Dimming

AC Input Cable(Exposed Length 300±10mm):

UL/EU model: 18AWG 105°C 600V O.D: 2.77mm,Black:ACL,White:ACN,Green:⊕

SPD Input Cable With Terminal (Exposed Length 260±10mm):

UL/EU model: 18AWG 105°C 600V O.D: 2.77mm,Green:SPD

DC Output Cable(Exposed Length 300±10mm):

UL/EU model: 18AWG 105°C 300V O.D: 1.95mm,Red:V+ , Black:V-

DIM Cable(Exposed Length 220±10mm):

UL/EU model: 22AWG 105°C 300V O.D: 1.52mm , Purple : DIM+, Pink: DIM-

Name Description	Standard Code	mm(In.)
Case Length	L3	181(7.13)
Case Width	W2	45(1.77)
Case Height	H	34(1.34)
Overall Length	L1	197(7.76)
Mounting Hole Length	L2	190(7.48)
Mounting Hole Width	W1	32(1.26)
TC Point Position	X	28(1.1)
TC Point Position	Y	24(0.94)

Note :

1,Please follow the "LED Driver User Manual" obtained from SOSEN's official website for assembly.

2,AC Input Cable,DC O/P Cable,DIM Cable:
Tinned length of wire:10±2mm

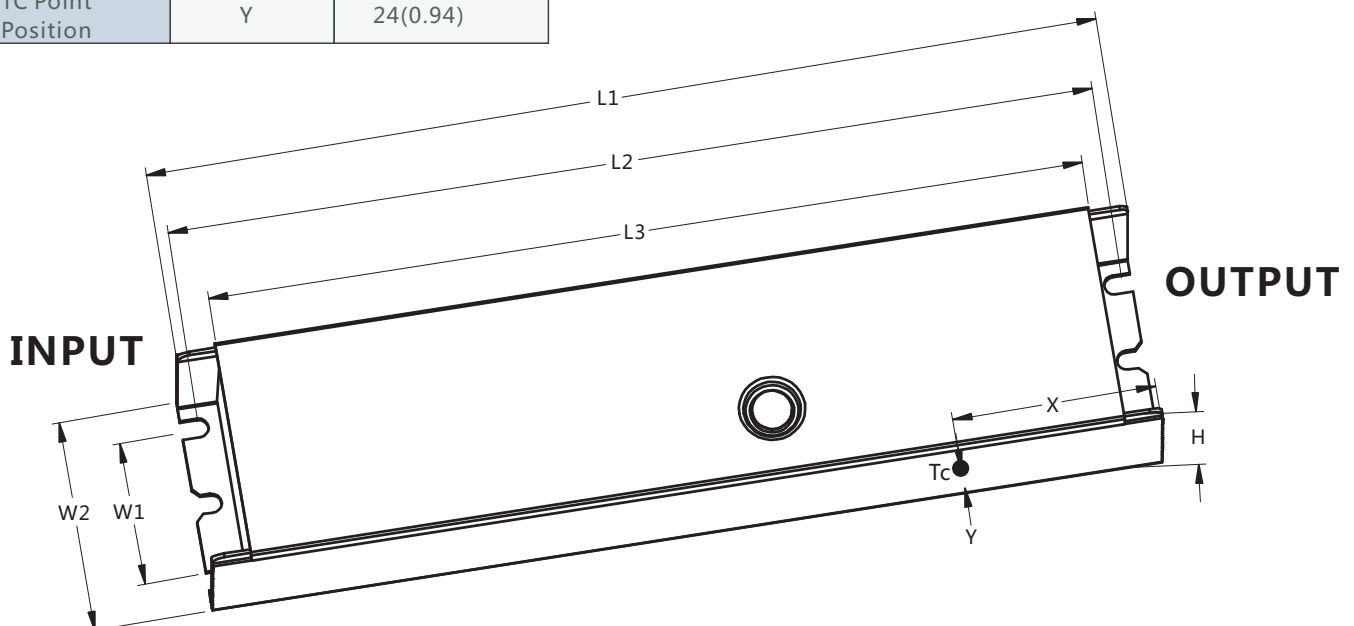

SS-200NL-E Series LED Driver



Assembly Tips

1. Highly recommended to seal the adjustable hole with silicon glue(#704 preferred) after adjusting the Driver's output current. Avoid permanent damage to adjust the potentiometer with suitable strength.
2. Dimming or AUX Power tinned connectors should be capped if not used to avoid dimming or AUX Power parts damage from external signals.
3. In order to meet the requirements of the power derating and the maximum ambient temperature of 50°, an auxiliary heat sink must be added. It is recommended that the heat sink has a heat dissipation area of 380cm² and volume of 115cm³. Thermal grease should be applied between led driver and the auxiliary heat sink to ensure the bottom of housing is in close contact with the heat sink.
4. The surge protection of the LED drivers meets the requirements of CM 6kV/DM 6kV. There is SPD inside the LED drivers. During test HI-POT between the PE and the primary, disconnect the SPD PE wire, then after tested, lock the SPD PE wire to housing and ensure contact is good.
5. Withstand voltage of dielectric layers between aluminum PCB and LED > 2.3KV.
6. Safety space between aluminum base and LED coppers > 5mm.
7. Safety space/coppers between LED+ and LED- > 1.8mm.
8. Minimize the copper area on the aluminum PCB to reduce parasitic capacitance and leakage current.
9. It is recommended to design LED beads in parallel first and then in series.
10. SOSEN reserves the right of final interpretation of the above parameters.

Package

- Outside carton dimension: L×W×H = 495mm×385mm×162mm;
- 24PCS/Carton;
- Net weight/Piece: 0.53kg;Gross weight/Carton: 14.6kg;
- Please refer to the product name, model number, manufacturer identification, QC PASS, manufacturing date on the package.

Transportation

Packaging is designed suitable for transportation by trucks, vessels and flights. The products should be avoided direct sunlight and rain, loaded/unloaded with caution.

Storage

The product storage meets the standard of the GB 3873 - 83.
Products should be rechecked if stored for over 1 year before assembly.

RoHS

Products comply with RoHS Directive (2011/65/EU) and amendment 2015/863/EU.

Revision History

Version	Description of Update	Updated Date	Remark
V00	Original Release	2022/08/26	
V01	Add SPD Input Cable	2022/10/26	
V02	Add Page Number	2023/02/01	